

10-IM-2500-A

Max. 3000 kg - 8 mm - 5.5 Hz

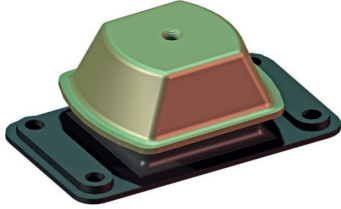

IM-Mountings are very suitable for mobile applications. These compact antivibration mountings are easy to install and offer a high level of vibration insulation. The integrated rebound control-device limits excessive movement under shock loads. IM-Mountings are available in several rubber mixes to accommodate a large load range. These mountings can be supplied with a height adjustment feature.

Applications: marine propulsion-engines, generator sets, pump units, compressor sets, etc.



SIDE-VIEW

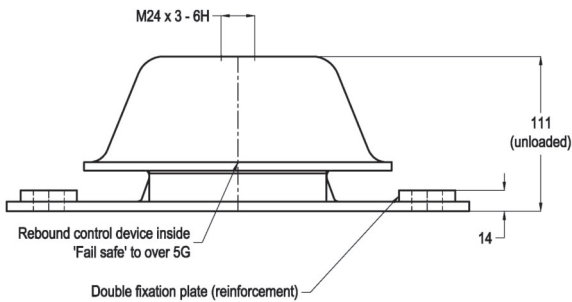

LOAD CHARACTERISTICS

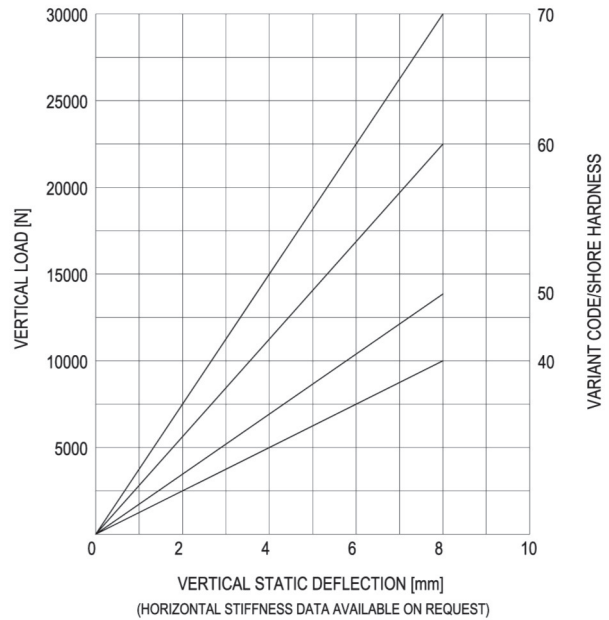

TOP-VIEW

